



CARIBUL S.r.l.

Via Marconi ,2
 Antivibranti metallici ed in gomma
 26866 Castiraga Vidardo (LO)
 Tel. 0371217078 Fax 0371217079



Antishock per presse meccaniche
 Cabine di insonorizzazione
 Rilievi fonometrici , analisi di vibrazioni,
 Equilibratura corpi rotanti

CARIBUL®

Sito : www.caribul.com
 E-Mail : info@caribul.com - commerciale@caribul.com - tecnico@caribul.com

Antivibranti multidirezionali in gomma speciale antiolio adatti alla sospensione di motori diesel, compressori e gruppi elettrogeni montati a bordo di mezzi semoventi .

Multi-directional oil resistant damping devices suitable to suspend diesel engines, air compressors, power units installed on moving machines

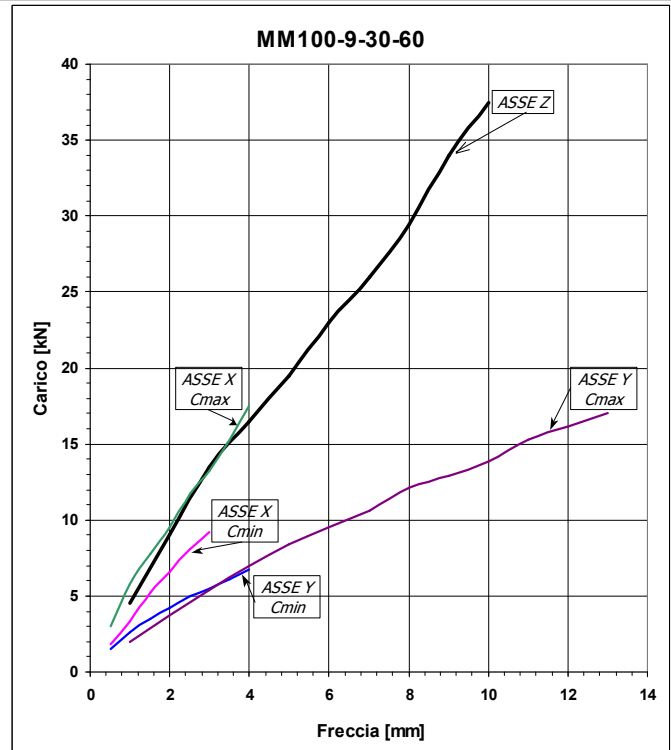
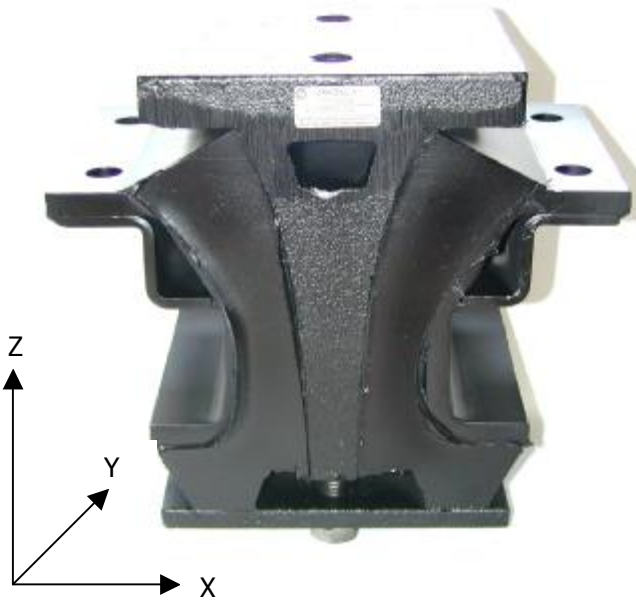

Inserto Centrale in EN GJL 250 – Ali appoggio in FeP11 - Elem. Elastico in gomma TSN durezza 60 Sh.A
 Central body made of EN GJL 250 – Wings material FeP11 – Elastic absorber TSN rubber hardness 60 Sh.A

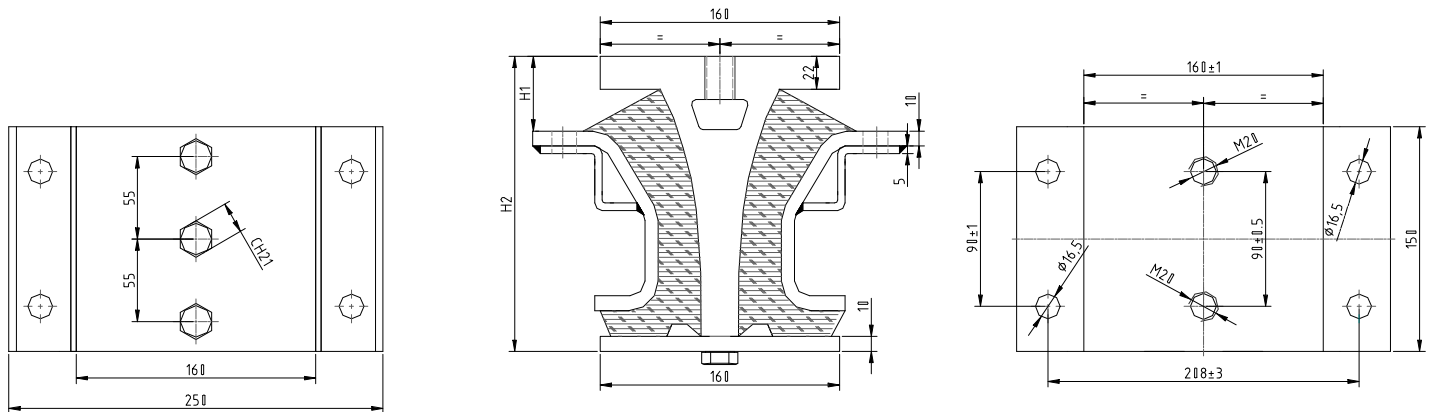

Serie	H1	H2	Portata Z		Freq. Propria Z		Freq. Propria X		Freq. Propria Y		Peso [kg]
	Libero [mm]	Libero [mm]	C _{min} [daN]	C _{Max} [daN]	C _{min} [Hz]	C _{Max} [Hz]	min [Hz]	max [Hz]	min [Hz]	max [Hz]	
MM100-9-30-60	50	197	900	3300	11	6.5	8	26	4	20	15

Tolleranze dimensionali ± 3 mm – Linear tolerances ± 3 mm