



CARIBUL S.r.l.

Via Marconi ,2
26866 Castiraga Vidardo (LO)
Tel. 0371217078 Fax 0371217079

CARIBUL®

E-Mail : info@caribul.com

Sito : www.caribul.com

Antivibranti in gomma, completamente metallici ed a molla per il settore industriale, navale, civile e militare.

Cabine di insonorizzazione.

Rilievi fonometrici e vibrazionali.

Rubber Antivibrations, Fully metallic vibration-dampers, Wire Rope Dampers, Spring damper, Viscous-spring Dampers, for industrial, civil, shipbuilding and military sector.

Soundproofing booths.

Phonometric and vibration analyses.

Antivibranti/antishock in gomma speciale testati secondo MIL 901-D e MIL 167

Special rubber mounts for antivibration/antishock purposes tested according MIL 901-D and MIL 167

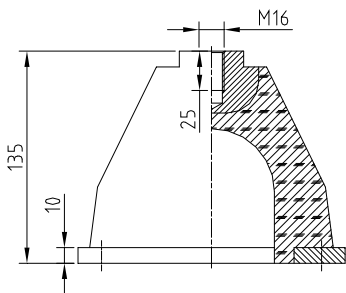

Deflessione max sotto shock:

Verticale: 65 mm

Orizzontale: 45 mm

Max Shock deflection:

Vertical: 65 mm

Horizontal: 45 mm

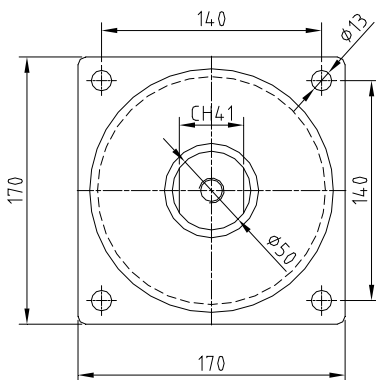

SM170 – SM 270

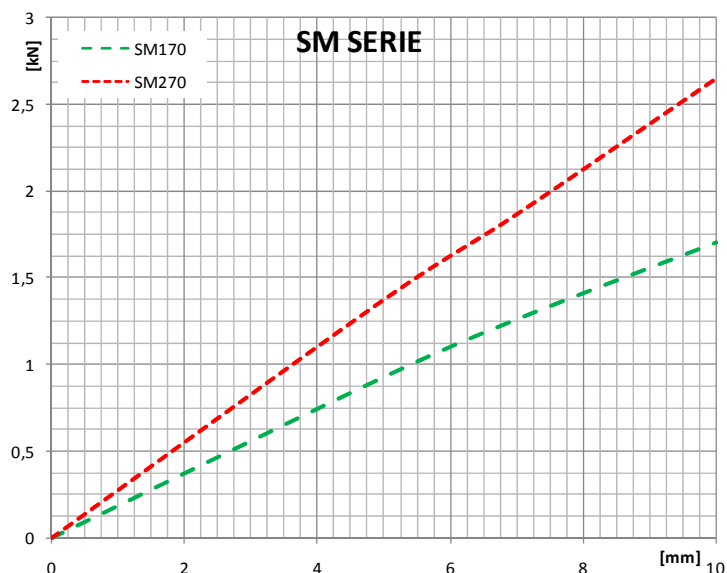

I supporti serie "SM" sono ideati per installazioni di apparati ove è richiesta una frequenza propria medio-bassa, unitamente ad esigenze di resistenza a valori di accelerazioni elevate, con relativi ampi spostamenti sotto shock. Il resiliente, realizzato in gomma speciale NBR antioil, antiozono ed antisalsedine, ne consente l'utilizzo in ambienti aggressivi e con temperature di esercizio comprese tra -30 e +70°C. Gli elementi metallici sono trattati mediante zincatura elettrolitica o verniciatura protettiva.

A richiesta particolari metallici in AISI316

"SM" series mounts are suitable for installations requiring medium-low eigenfrequencies, along with high acceleration resistance and large displacement requirements under shock conditions. The core, built of special NBR rubber, oil, ozone and saltiness proof, can endure hard environments and temperatures from -30°C (-22°F) up to +70°C (158°F). Metal parts are zinc or paint coated.

On request metallic parts made of AISI316

Model	Load [daN]		Vert Stiffness [daN/mm] (*)	Static Vert deflect [mm]		Natural Frequency [Hz] (Vs. load)		Dynamic Frequency [Hz] (Vs. load)		Dynamic Amplif. At resonance (Vs. load)		Mass [kg]	Rubber Hard. [ShA]
	Min	max		Min	max	Min	max	Min	Max	Min	Max		
SM170	90	170	11.4	5	10	7.0	5.0	14.5	8.9	5.6	4.8	3.4	50
SM270	145	270	24.7					14.3	10.3	4.5	4.4		

(*) Calcolata tra il 75% e il 100% del carico massimo

(*) Calculated in the range between 75% and 100% of maximum load